



HAYWARD HIGH PERFORMANCE PUMPS INSTALLATION AND OPERATING INSTRUCTIONS

Power-flo™ LX SERIES

Your Hayward centrifugal pump has been quality built and engineered to give you many years of efficient, dependable service.

The advanced design reduces operation and maintenance to simple, common-sense procedures.

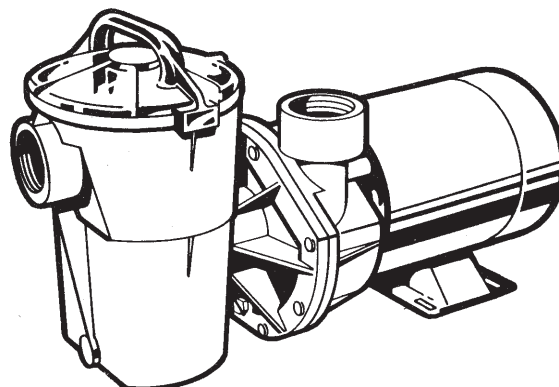

GENERAL TIPS ON PUMP INSTALLATION

For best pump performance, locate the system below the pool water line and as close to the pool as practical. *If you own an above-ground pool, please see Note: NSPI-4 Article V, for safe and proper installation of the equipment package.* Make sure suction joints are tight. Suction pipe should be as large or larger than discharge pipe.

Damp, non-ventilated locations should be avoided. Motors require free circulation of air to aid in cooling.

Insure that the electrical supply available agrees with the motor's voltage, phase and cycle, and that wire size is adequate for the HP (KW) rating and distance from power source. Motor must always be properly grounded. If cord connected, use only a properly grounded outlet. Electrical circuits must be protected by proper size ground fault circuit interrupter (GFCI) as required by applicable electrical codes. All electrical wiring must be performed by qualified personnel, and must conform to local codes and regulations.

STARTING AND PRIMING INSTRUCTIONS

Fill strainer housing with water to suction pipe level. Never operate the pump without water. Water acts as a coolant and lubricant for the mechanical shaft seal.

Open all suction and discharge lines and valves, as well as air bleed (if available) on filter. (The air that is to be displaced from the suction line must have some place to go.) **Caution: All suction and discharge valves must be open when starting the system. Failure to do so could result in severe personal injury and/or property damage.**

Turn on power and allow a reasonable time for priming. Priming time depends on suction lift and horizontal length of suction piping. If the pump will not start, or will not prime, see TROUBLE SHOOTING GUIDE on back page.

NOTE: NSPI-4 Article V, standard for above-ground and on-ground pools, advises that components such as the filtration system, pumps and heater be positioned so as to prevent their being used as a means of access to the pool by young children.

MAINTENANCE

1. Clean strainer basket regularly. Do not strike basket to clean. Inspect strainer cover gasket regularly and replace as necessary.
2. Hayward pumps have self-lubricating motor bearings and shaft seals. No lubrication is necessary.
3. Keep motor clean. Insure air vents are free from obstruction.

4. Occasionally, shaft seals must be replaced, due to wear or damage. See instructions.

STORAGE/WINTERIZING

Pump and motor must be protected from freezing. Shut off all electric power. Disconnect cord/electrical connections and plumbing connections. Drain thoroughly and clean out any debris. Store pump and motor in a dry, well-ventilated room.

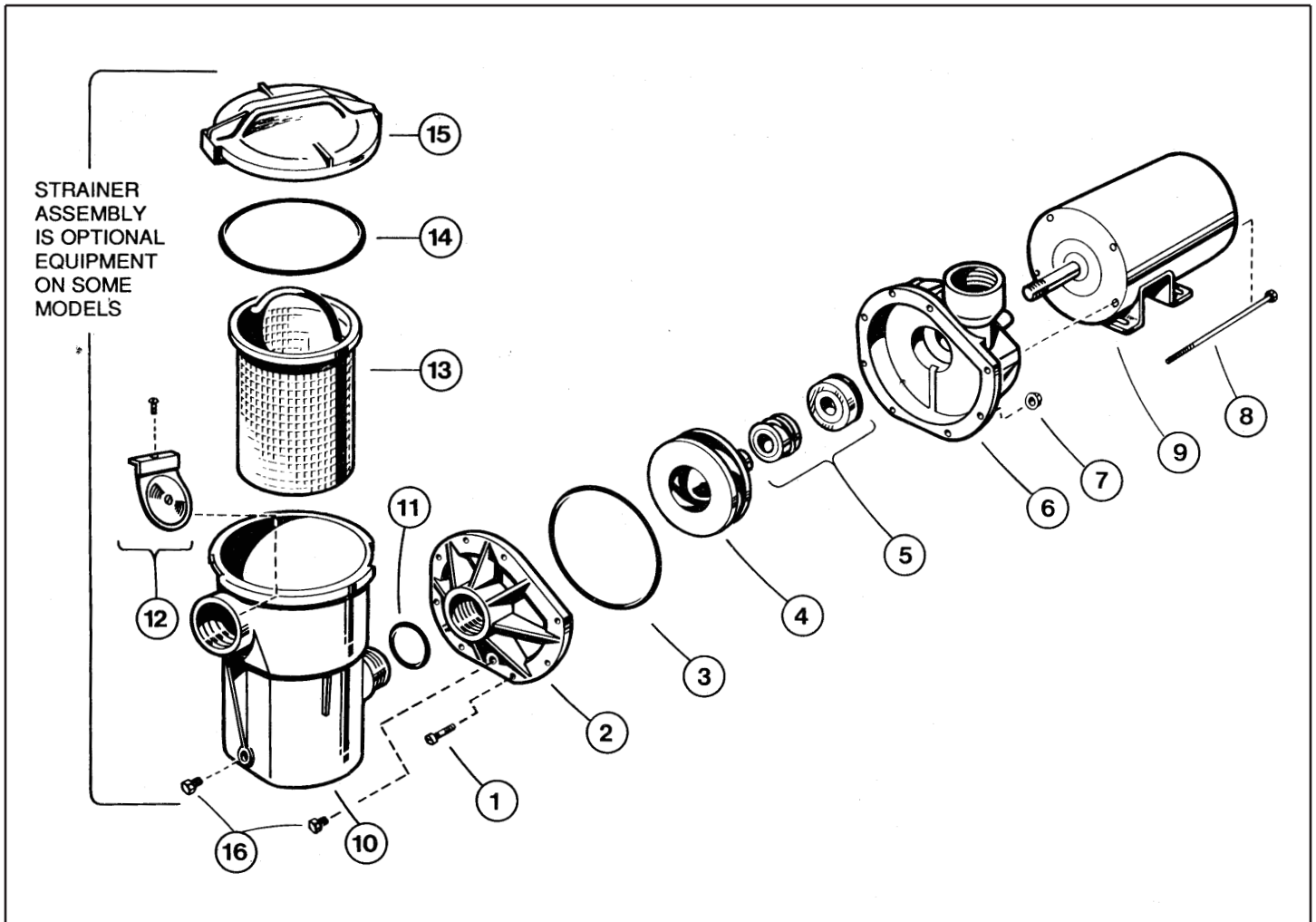

DWG. NO.	DESCRIPTION	NO. REQ'D.	PART NUMBER			
			MODEL SP-1575LX	MODEL SP-1580	MODEL SP-1580X15	MODEL SP-1585X20
1	Bolt, No. 10-24 Hex. Head	8	SPX1500-N2	SPX1500-N2	SPX1500-N2	SPX1500-N2
2	Housing Cover	1	SPX1580-BP	SPX1580-BP	SPX1580-BP	SPX1580-BP
3	Housing O-Ring	1	SPX1580-Z-1	SPX1580-Z-1	SPX1580-Z-1	SPX1580-Z-1
4	Impeller	1	SPX1500-F	SPX1500-L	SPX1500-L	SPX1580-C
5	Seal Assembly	1	SPX1250-XZ-2	SPX1250-XZ-2	SPX1250-XZ-2	SPX1250-XZ-2
6	Pump Housing	1	SPX1580-AAP	SPX1580-AAP	SPX1580-AAP	SPX1580-AAP
7	Nut, No. 10-24 Hex.	8	SPX1500-Y-2	SPX1500-Y-2	SPX1500-Y-2	SPX1500-Y-2
8	Motor-to-Housing Bolt	4	To order, specify motor manufacturer, HP and pump model no.			
9	Motor	1	SPX1510-Z-1E	SPX1510-Z-1XE	SPX1515-Z-1E	SPX1525-Z-1E
10	Strainer Housing	1	SP-1500-CP	SP-1500-CP	SP-1500-CP	SP-1500-CP
11	O-Ring	1	SPX1500-W	SPX1500-W	SPX1500-W	SPX1500-W
12	Check Valve Assembly (Optional)	1	SPX1500-RA	SPX1500-RA	SPX1500-RA	SPX1500-RA
13	Basket	1	SPX1500-LX	SPX1500-LX	SPX1500-LX	SPX1500-LX
14	Strainer Cover O-Ring	1	SPX1500-P	SPX1500-P	SPX1500-P	SPX1500-P
15	Strainer Cover	1	SPX1500-D-2	SPX1500-D-2	SPX1500-D-2	SPX1500-D-2
16	Drain Plug w/Gasket	2	SPX1700-FG	SPX1700-FG	SPX1700-FG	SPX1700-FG
---	Strainer Shim Ring	1	SPX1500-X1	SPX1500-X1	SPX1500-X1	SPX1500-X1
---	6 Ft. Cord (Not Shown)	1	SPX1500-WA	SPX1500-WA	SPX1500-WA	

SEAL CHANGE INSTRUCTIONS

POWER FLO™ LX SERIES

GENERAL

Exercise extreme care in handling and installing the new seal and ceramic seat assembly. The lapped and polished surfaces may easily be damaged by dirt or scratching.

For safety, all service must be performed with **all power shut off.**

1. Remove pump and motor assembly from piping system.
2. Remove pump housing cover (with strainer attached) by removing the eight (8) housing bolts and nuts which fasten housing cover to pump housing. The impeller is now exposed.
3. To remove impeller, insert screwdriver in slot at end of motor.* Hold screwdriver so as to keep shaft from turning, and rotate the impeller in a counterclockwise direction. The spring portion of the seal assembly is now exposed.
4. Note carefully the position of the spring seal and pull it off the impeller.
5. To remove the stationary (ceramic seat) part of the seal assembly:
 - a. Loosen the four (4) motor securing bolts and disengage the motor from the pump housing.
 - b. With motor removed, press the clear plastic and ceramic seat assembly out of the pump housing recess. If tight, tap lightly from the "motor" side.
6. Clean and lubricate the impeller hub shaft and pump housing seal recess with a dilute solution of non-granulated liquid-type soap. The use of petroleum or silicone lubricants can contribute to seal leakage.
7. Press the new spring portion of the assembly onto the impeller, black polished surface facing away from the impeller.
8. Carefully press ceramic seat, with O-ring, into clear plastic seat retainer—polished surface facing out. Be sure O-ring is in place on cut ridge of clear plastic retainer. Press plastic retainer, with ceramic seat inside, into recess of pump housing—O-ring end first. Replace the assembly firmly and evenly.
9. Carefully insert the motor shaft through the seat assembly, and secure motor to pump housing with four (4) motor securing bolts. (Be sure motor base is positioned properly.)
10. Screw the impeller, with spring seal, onto the motor shaft, hand tight, by turning clockwise.
11. Clean fiber gasket (replace if necessary) and fasten housing cover to pump housing with eight (8) bolts and nuts. Tighten bolts and nuts alternately and evenly.
12. Reconnect pump to piping system. Be sure to fill strainer with water before restarting.

*For A.O. Smith Canopy Style Motors: Remove motor end cover and *carefully* apply wrench to flat on motor shaft to hold shaft from turning.

ELECTRICAL GUIDE — 60 CYCLE MOTORS — SINGLE PHASE

MOTOR		VOLTS	CIRCUIT BREAKER RATINGS - AMPS	BRANCH FUSE/RON RATINGS - AMPS	RECOMMENDED WIRE SIZE 0-50'
KW	HP				
.55	3/4	115	15	15	#14
.75	1	115	20	20	#12
1.1	1-1/2	115	20	20	#12
1.55	2	230	15	15	#14

A separate electrical circuit, utilizing a rating as above, is recommended.

TROUBLE SHOOTING GUIDE

A. MOTOR WON'T START

1. Check for improper or loose connections, open switches or relays, blown circuit breakers or fuses.
2. Manually check rotation of motor shaft for free movement and lack of obstruction.

B. MOTOR CUTS OUT—Check for:

1. Wiring, loose connections, etc.
2. Low voltage at motor (frequently caused by undersized wiring).
3. Binding and overload. (Amperage reading)

NOTE: Your Hayward pump motor is equipped with Automatic Thermal Overload Protection. The motor will automatically shut off, under normal conditions, before heat damage build-up, due to an improper operating condition, can occur. The motor will auto-restart when safer heat level is reached.

C. MOTOR HUMS, BUT DOES NOT START— Check for:

1. Centrifugal switch stuck in open position.
2. Binding of motor shaft.

D. PUMP WON'T PRIME

1. Make sure pump/strainer housing is filled with water and that cover O-ring is clean and properly seated. Make sure strainer cover is locked firmly in position.
2. Make sure all suction and discharge valves are open and unobstructed, and that pool water level is above all suction openings.
3. Block off suction as close to pump as possible and determine if pump will develop a vacuum.

a. If pump develops a vacuum, check for blocked suction line or strainer, or air leak in suction piping.

b. If pump does not develop a vacuum and pump has sufficient "priming water":

1. Tighten all bolts and fittings.
2. Check voltage to make sure pump is up to speed.
3. Open pump and check for clogging or obstruction.
4. Remove and replace shaft seal.

E. LOW FLOW—Generally, check for:

1. Clogged or restricted strainer or suction line; undersized pool piping.
2. Plugged or restricted discharge line of filter (high discharge gauge reading).
3. Air leak in suction (bubbles issuing from return fittings).
4. Pump operating underspeed (low voltage).
5. Plugged or restricted impeller.

F. NOISY PUMP—Check for:

1. Air leak in suction causing rumbling in pump.
2. Cavitation due to restricted or undersized suction line and unrestricted discharge lines. Correct suction condition or throttle discharge lines, if practical.
3. Vibration due to improper mounting, etc.
4. Foreign matter in pump housing.
5. Motor bearings made unserviceable by wear, rust, or continual overheating.

SERVICE & REPAIRS

Consult your local Hayward dealer or service center.

No pumps or motors may be returned directly to the factory without the expressed written authorization of Hayward Pool Products, Inc.



HAYWARD POOL PRODUCTS, INC.

Hayward Pool Products, Inc.
900 Fairmount Avenue
Elizabeth, NJ 07207

Hayward Pool Products, Inc.
2875 Pomona Boulevard
Pomona, CA 91768

Hayward Pool Products Canada
2880 Plymouth Drive
Oakville, Ontario L6H 5R4

Hayward S.A.
Zone Industrielle de Jumet
B - 6040 Charleroi (Belgium)